

SPORTS/RT *807P*



OWNER'S MANUAL ASSEMBLY INSTRUCTIONS

TABLE OF CONTENTS

A. INTRODUCTION.....	1
B. SAFETY GUIDELINES.....	2
C. ASSEMBLING YOUR ELLIPTICAL TRAINER	
INSTALLATION REQUIREMENTS.....	3
LIST OF PARTS.....	3
STEP BY STEP INSTRUCTIONS.....	4
LEVELING FEET.....	11
D. EXERCISING ON YOUR ELLIPTICAL TRAINER	
ELECTRONICS PACKAGE.....	12
MANUAL.....	12
SET.....	12
STRIDE ADJUSTMENT.....	13
PROGRAM.....	13
USING THE INTERVAL MODE.....	15
RESET.....	16
KEY FUNCTIONS (DEFINITIONS).....	16
HEART RATE CONTROL FEATURE (if applicable).....	17
E. GUIDLINES FOR EXERCISE.....	19
HOW LONG SHOULD I EXERCISE.....	19
HOW OFTEN SHOULD I EXERCISE.....	19
F. MAINTAINING YOUR ELLIPTICAL TRAINER	
CLEANING YOUR ELLIPTICAL TRAINER	19
G. TROUBLE SHOOTING	21
H. WIRING SCHEMATIC	23

SAFETY GUIDELINES

Please read and follow the below safety guidelines:

- Keep this owner's manual for future use and reference.
- Read this owner's manual and follow the instructions.
- Assemble and operate the elliptical trainer on a solid, level surface.
- Never allow children on or near the elliptical trainer.
- Check the elliptical trainer before every use. Make sure all parts are assembled correctly, and all fasteners are tightened. Do not use the machine if it is disassembled in any manner.
- Keep your hands and loose clothing away from moving parts.
- Wear proper workout clothing.
- Don't rock the unit from side to side, and take care when mounting and dismounting the unit.
- Only stand on provided foot pedals.
- Allow sufficient space on both sides of the elliptical for users to mount and dismount the machine.
- Do not use any accessories that aren't specifically recommended by the manufacturer as these might cause injuries or cause the unit to fail.
- If any parts fail or are defective, please stop your workout immediately and contact your dealer for repairs.
- If you feel any pain or discomfort, STOP YOUR WORKOUT and consult your physician immediately.

Caution:

Before beginning any exercise program, you should consult with your doctor. It is recommended that you undergo a complete physical examination.

INTRODUCTION

Congratulations on purchasing one of the finest pieces of exercise equipment on the market today. Constructed of high quality materials and designed for years of trouble-free usage, the elliptical will be an integral part of your health and fitness.

Before using your elliptical trainer, we recommend that you familiarize yourself with the owner's manual. Whether you are a first time user of an elliptical trainer or a seasoned "pro", understanding the correct use of the equipment will enhance your ability to achieve your exercise goals safely and successfully.

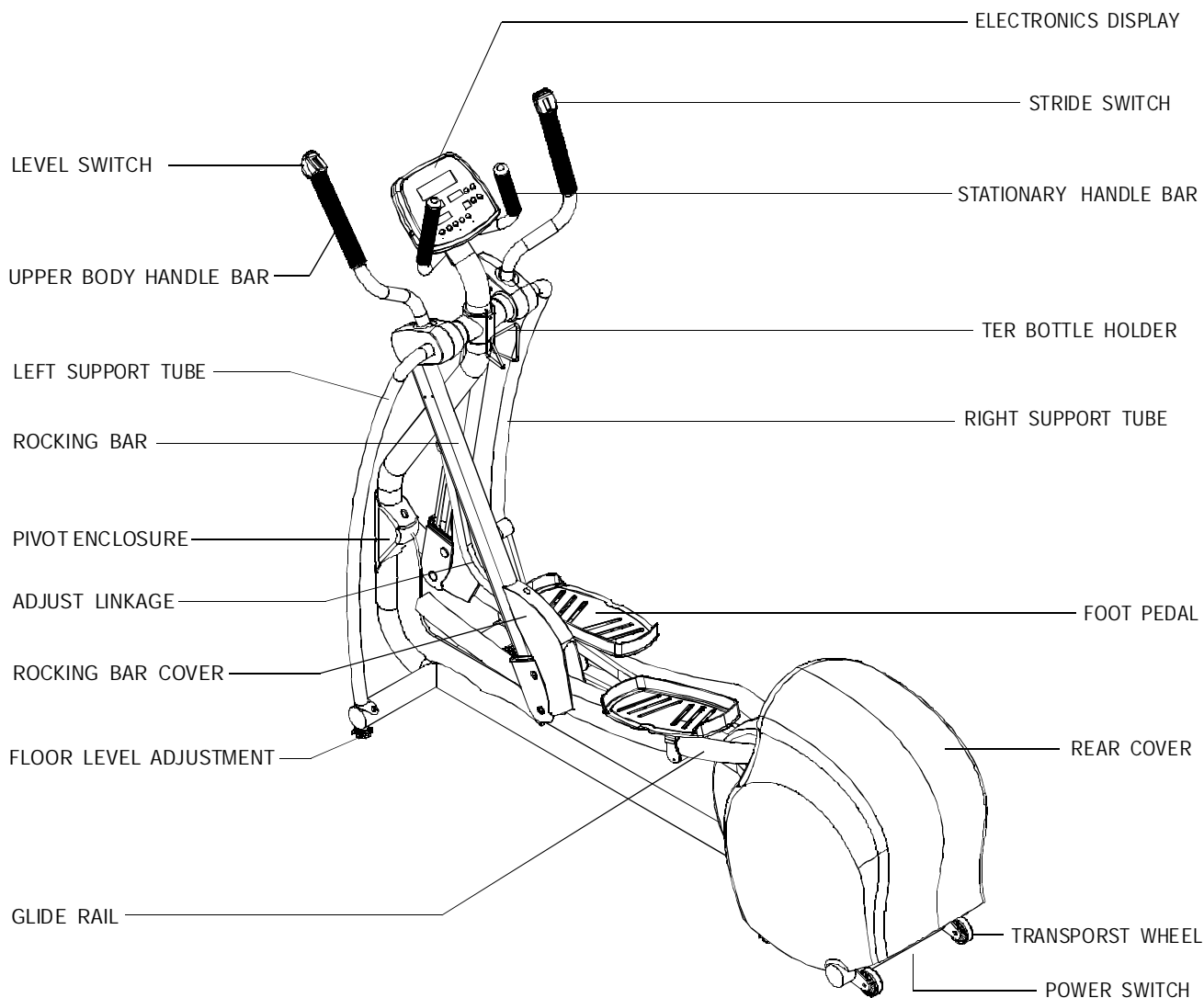

ASSEMBLING YOUR ELLIPTICAL TRAINER

INSTALLATION REQUIREMENTS:

Read this owner's manual and follow the instructions contained herein.

Important: The packing for this unit was designed to protect it during shipment. Please store the original packaging in a safe place in case you need to ship the unit in the future.

LIST OF PARTS:

Before assembling your elliptical, please make sure you have all the following items. If any items are missing, contact your authorized dealer.

1. Four 3/8" x L1" bolts - lift post and frame
2. Four 3/8" washers - lift post and frame
3. Two 3/8" x L3/4" bolts - lift post and frame
4. Two 5/16" x L1 3/4" bolts - moving bar and linkage
5. Two 5/16" washers - linkage
6. Four 5/16" x L19 bolts - support tube
7. Four 5/16" washers - support tube
8. Two 1/4" x L3/4" screws - rocking bar
9. Two 1/4" washers - rocking bar
10. Eight M5 x L12 PH screws - foot pedals
11. One M5 x L12 PH screw - rocking bar cover
12. Two M5 x L8 screws - water bottle holder
13. Double open end wrench 12 x 15
14. Hex Allen wrench M6
15. Hex Allen wrench M5
16. 2 - way Screwdriver
17. Hex Allen wrench M4

STEP BY STEP INSTRUCTIONS:

When you remove the Elliptical from its box, first check to make sure all of the parts are present. Then, read through the assembly instructions before you begin.

1. Remove only the upper box and Styrofoam. (see Fig 1)

Note: Do not remove the lower box and Styrofoam until you finished assembly step 5 (see Fig 4)

2. Raise the main post into position, and secure with the 3/8" bolts by wrench provided. (see Fig. 1)

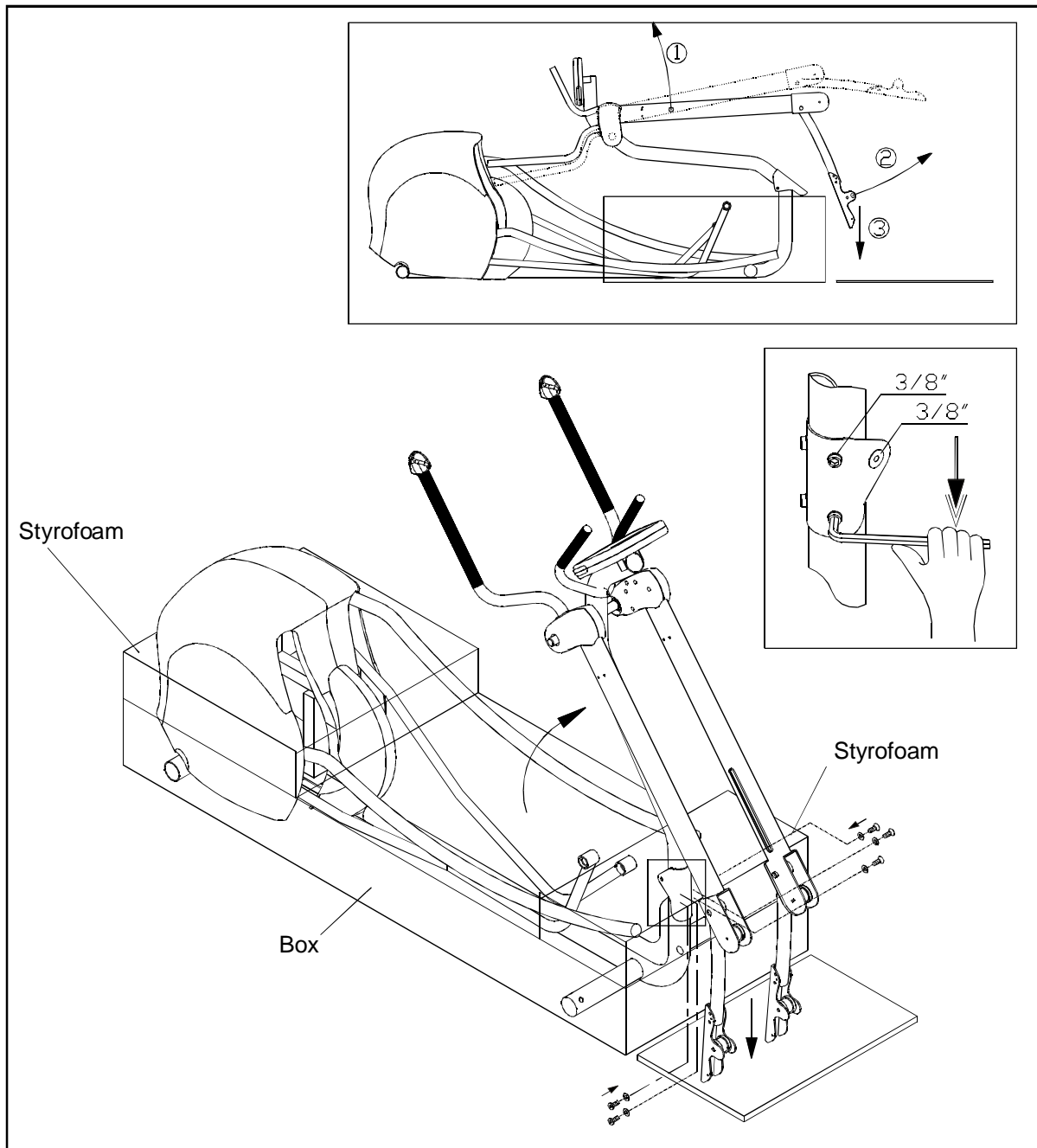

Fig.1

3. Remove the lower roller and shaft as shown in Fig. 2.

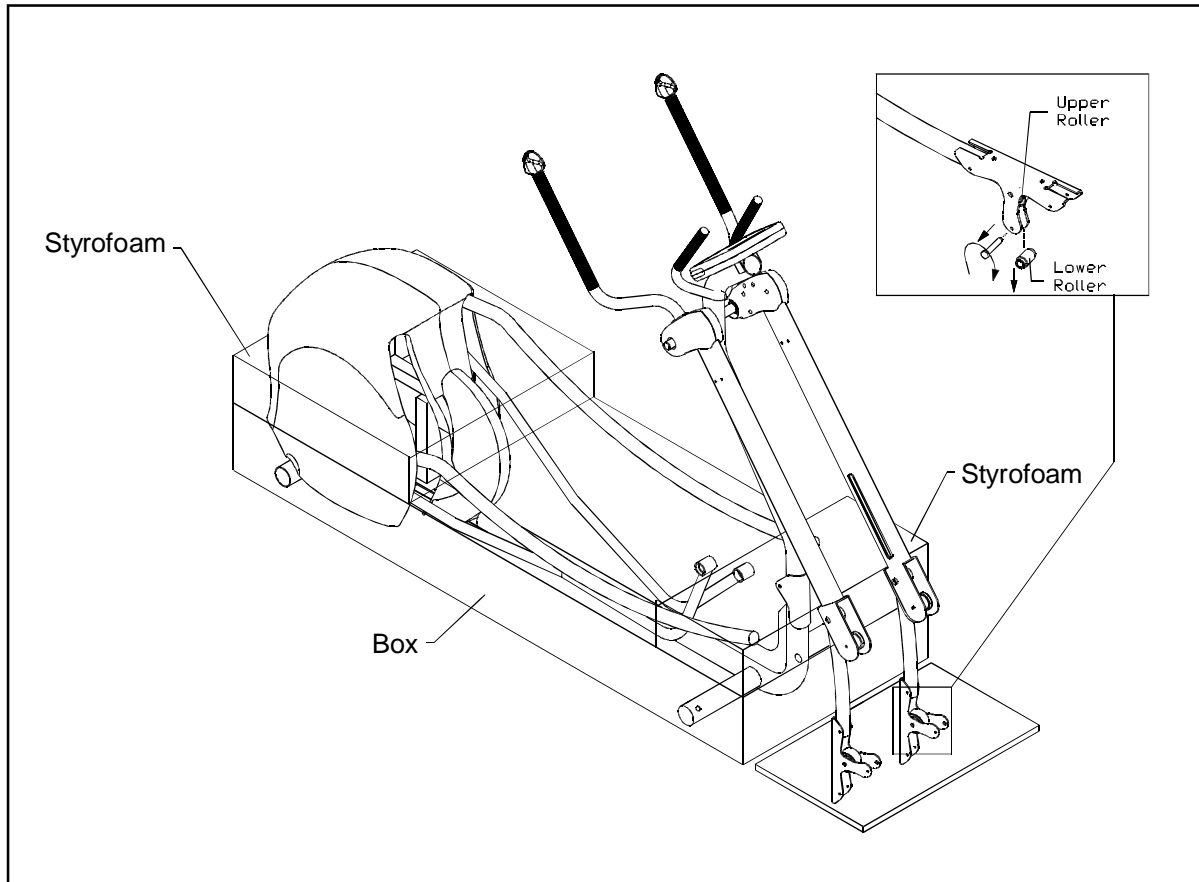

Fig.2

4. Place the glide rail over the rocking bar roller. (see Fig.3)

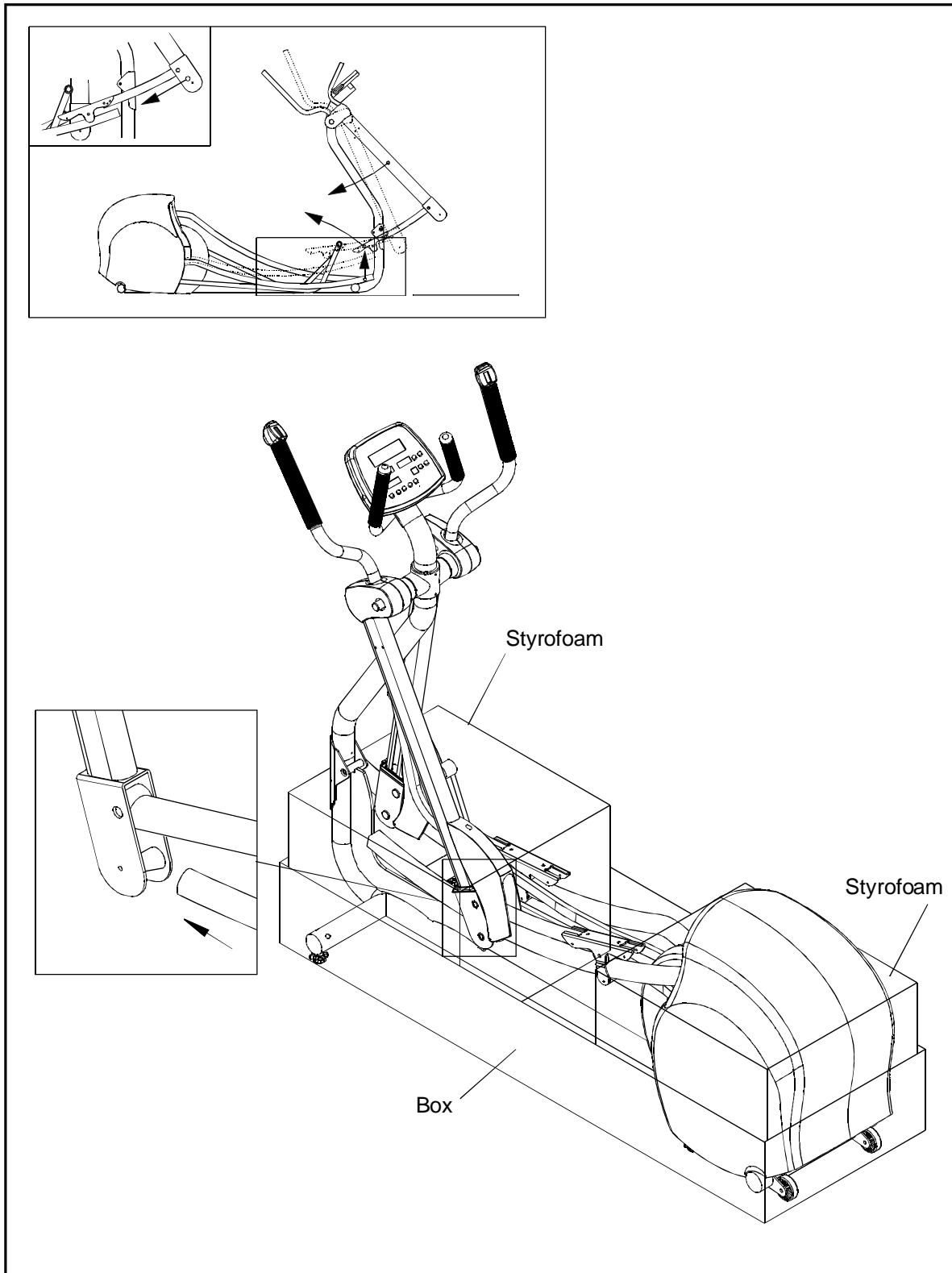

Fig.3

5. Insert the protrusion on the linkage into its place on the rocking bar and secure with screw as shown in diagram A, then cover with the end cap. Following that remove all the Styrofoam and packing box. (see Fig 4)

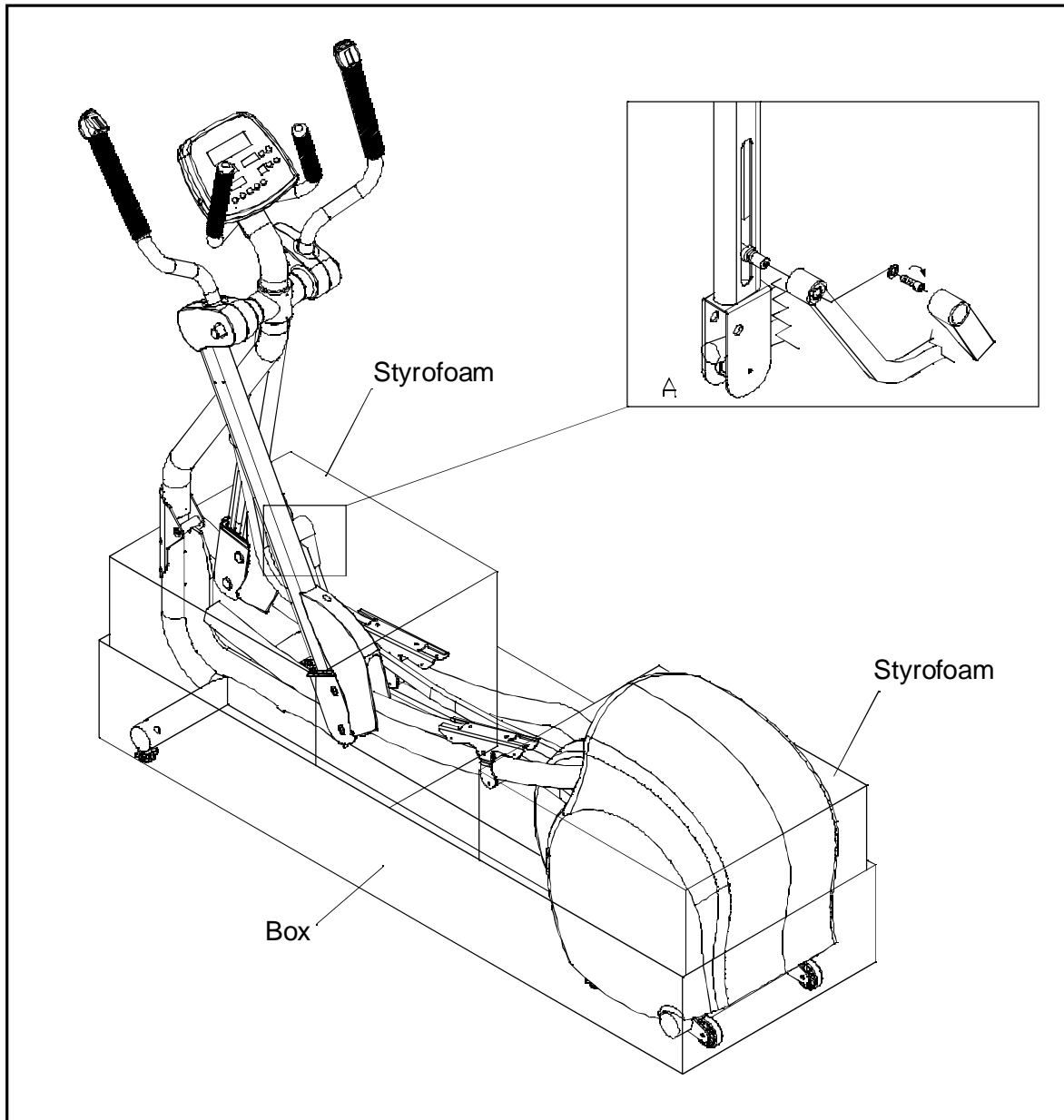

Fig.4

Remove all the Styrofoam and packing box.

6. Make sure the upper roller is located on the glide rail then fasten the foot pedals with screws. Secure the lower roller with the shaft and fasten the shaft by open-end wrench. (see Fig. 5)

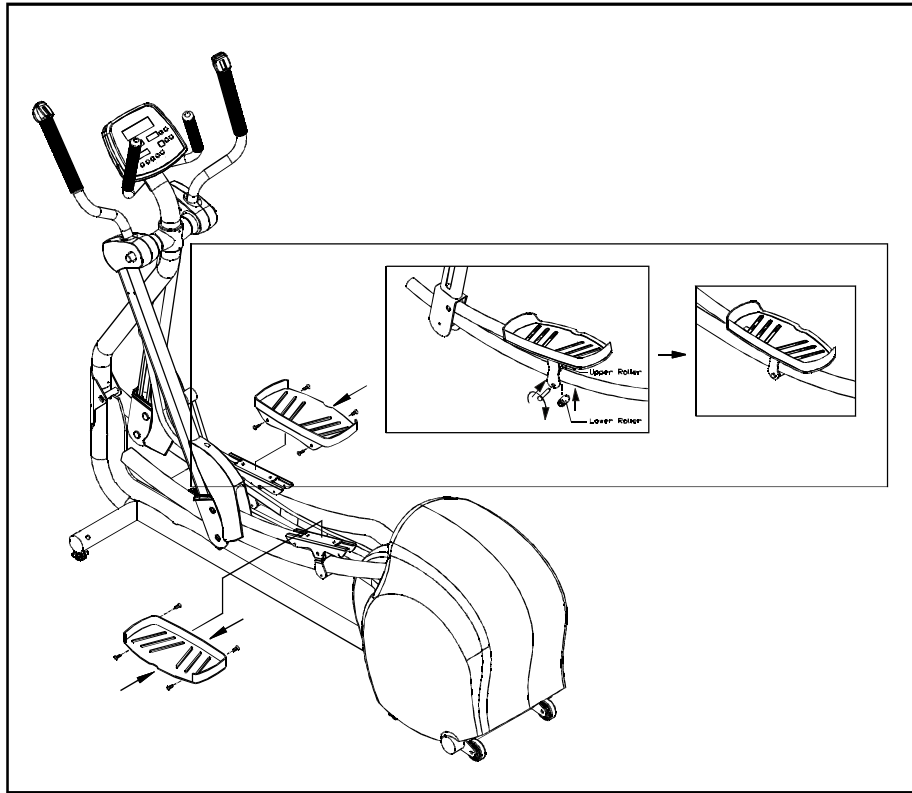

Fig.5

7. Tighten the pivot enclosure with the screw provided. (see Fig. 6)

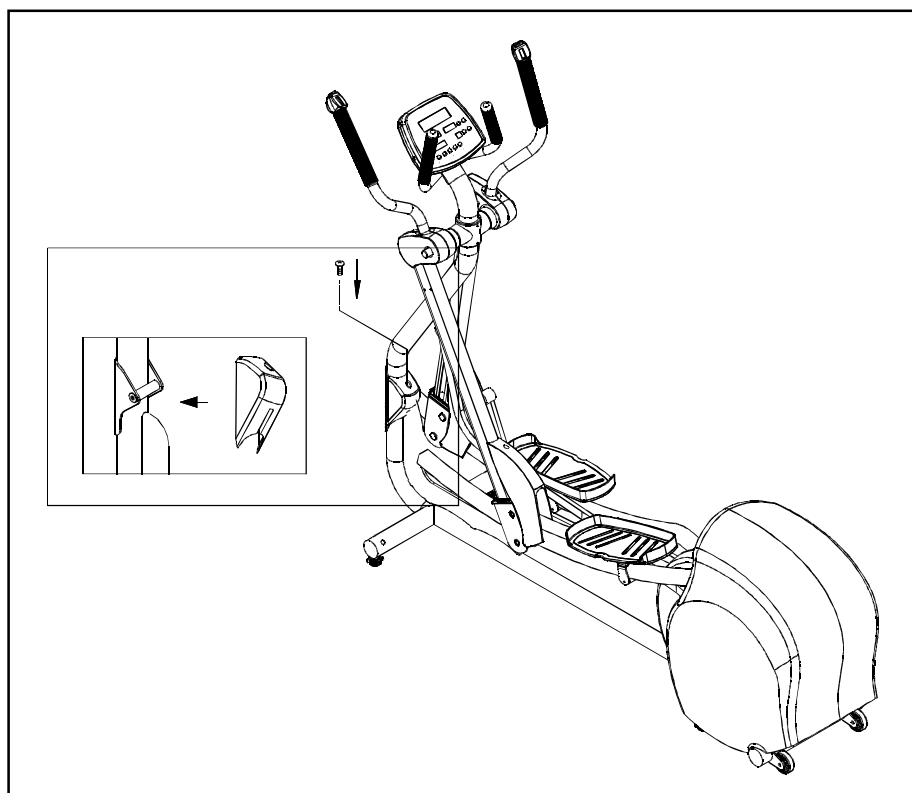

Fig.6

8. Fasten the screws to the glide rail as shown in diagram in Fig.7.

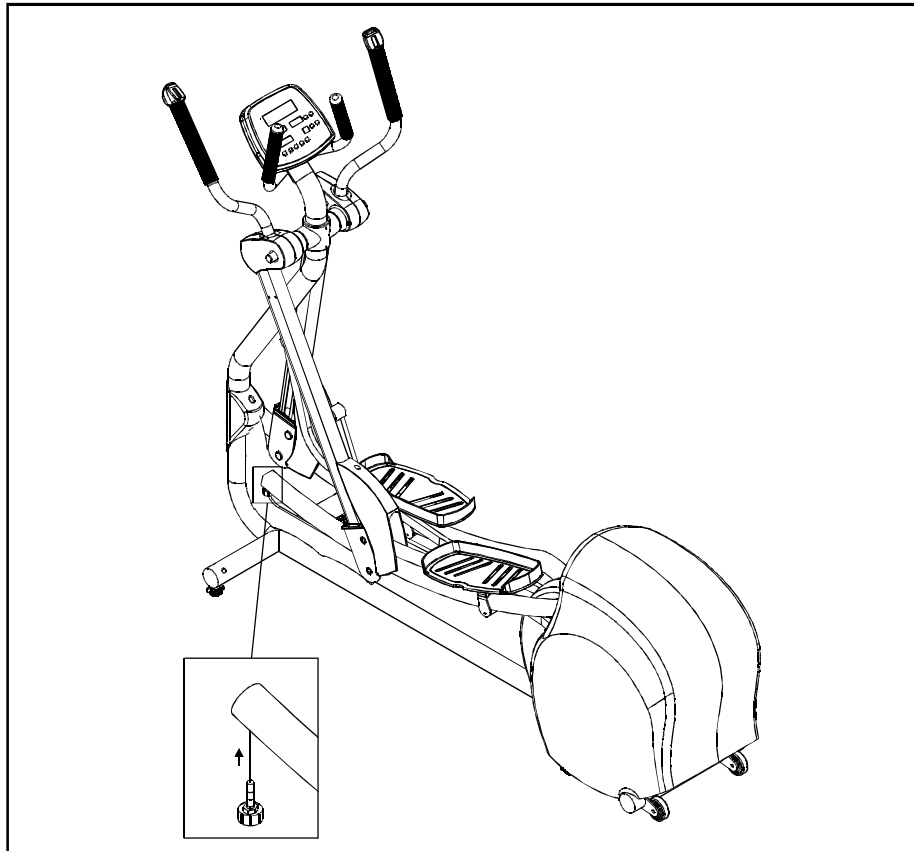

Fig.7

9. Attach the support tubes with the 1/4" x L 3/4" bolts to the upper tube mount, and secure them tightly. Use T-handle wrench to secure 5/16" x L 3/4" bolts on the lower tube mount. Then cover with water-against cap. (See Fig.8)

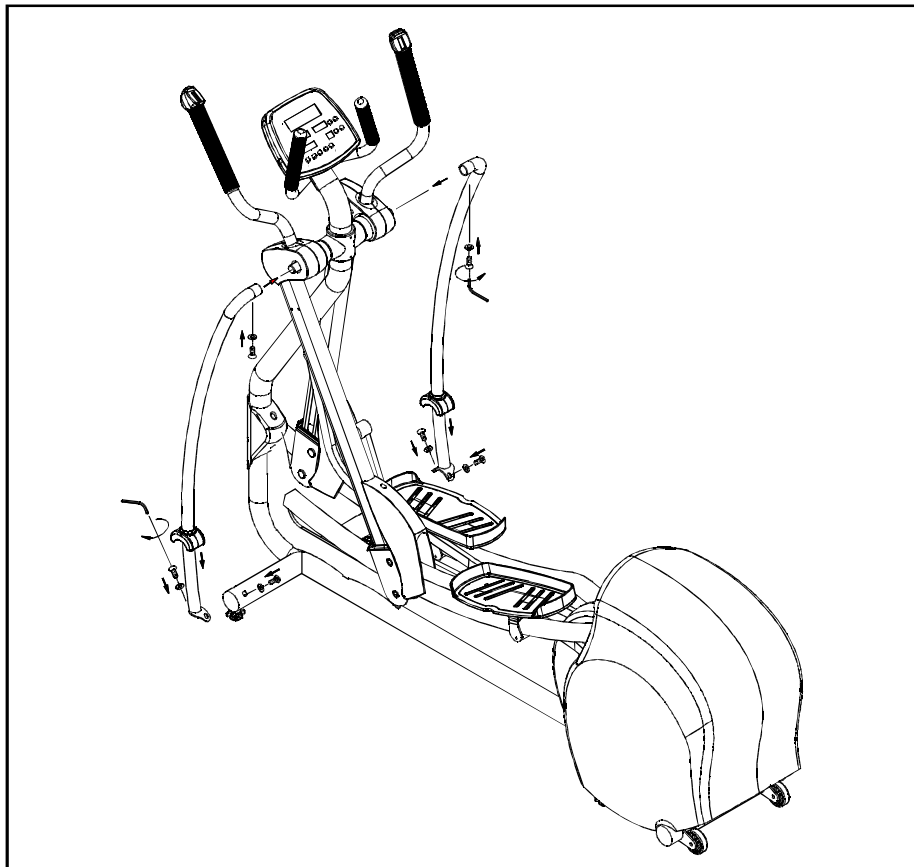

Fig.8

10. Screw the water bottle holder securely. (See Fig.9)

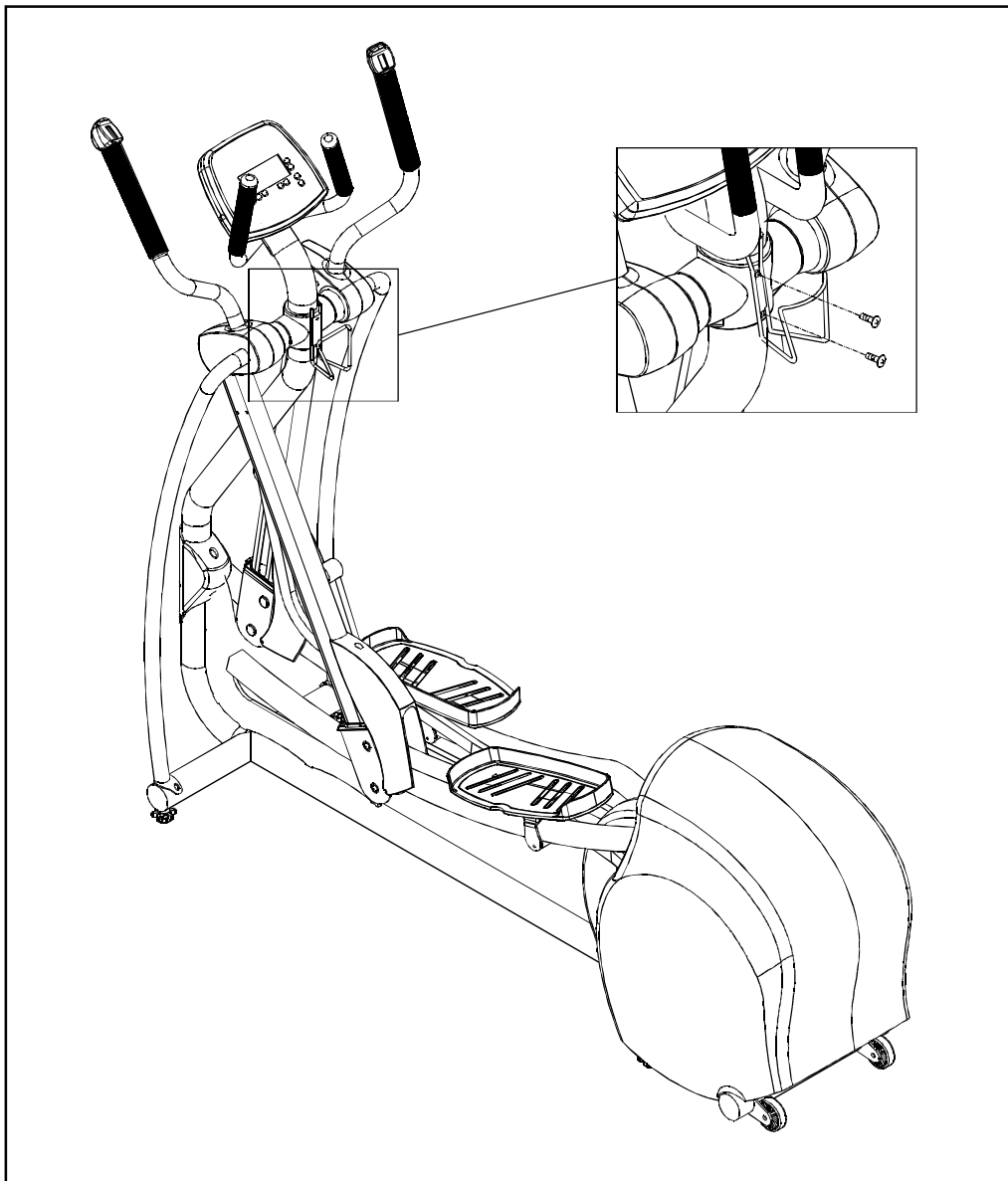

Fig.9

LEVELING FEET

If the elliptical is unsteady on the floor, adjust the leveling feet on the front of the machine. Raise or lower the leveling feet to steady the elliptical. (see Fig. 10).

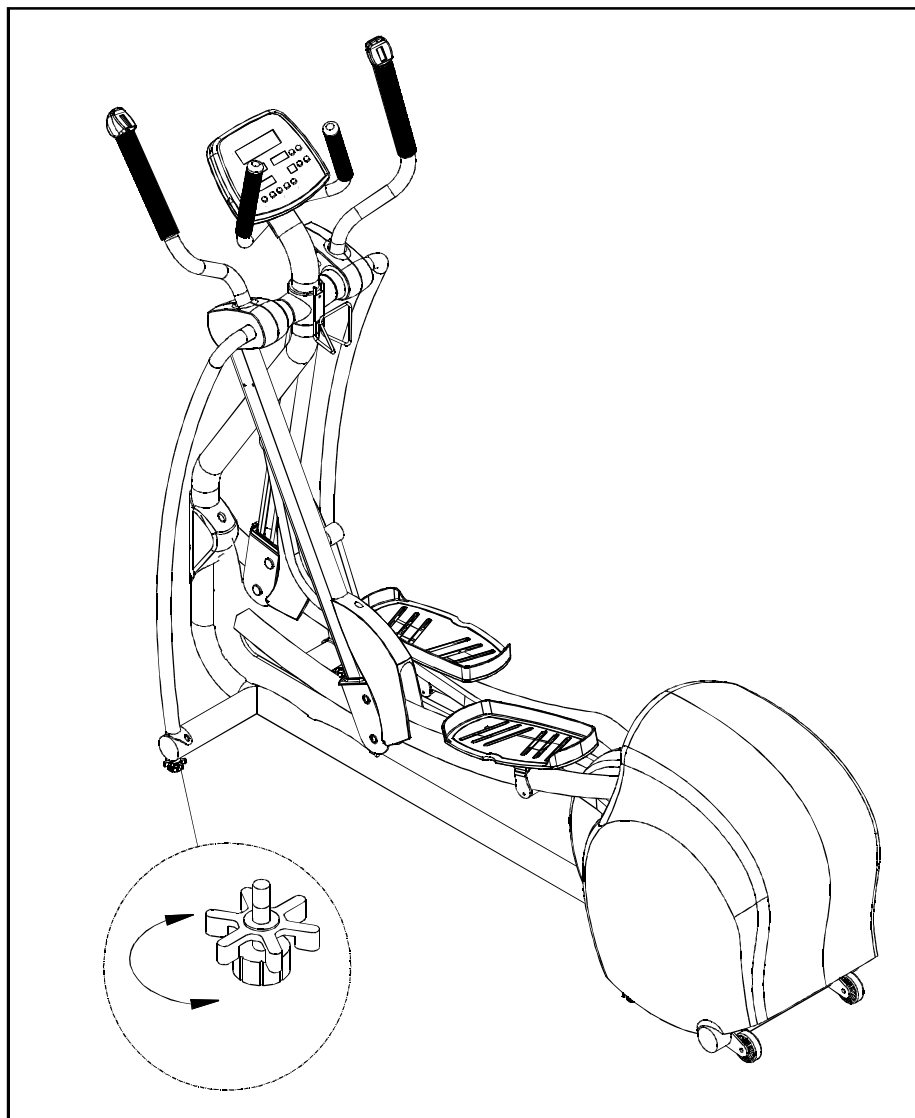

Fig.10

Your ELLIPTICAL is ready to use.

EXERCISING ON YOUR ELLIPTICAL TRAINER

ELECTRONICS PACKAGE

As soon as you turn on the machine, you will automatically enter the MANUAL Mode, the word MAN'L will be shown on and the unit defaults to a starting tension of LEVEL 5. If you want to start in the MAN'L mode, simply begin using the unit. If you stop your workout, STEP will appear in the display to remind you to continue your workout, and then the display will automatically return to MAN'L.

PLEASE NOTE: There are 14 levels, with Level 1 being the easiest workout (the steps with little tension), and LEVEL 14 being the hardest workout. Use the LEVEL ▲▼ keys to choose the desired level.

MANUAL:

1. When "MAN'L" appears in the display window, the display will prompt you to "STEP TO START".
2. Press the LEVEL ▲▼ button to choose your desired workout resistance.
3. If you stop in the middle of your workout, you will be prompted to STEP TO START, then the display will automatically return to MAN'L. All input data (TIME, STEPS, CAL., etc) will be retained.
4. You can use the MODE button to switch between TIME and STEPS. Use the MODE ▲▼ buttons to set the desired TIME or STEPS.
5. CALORIES, HEARTRATE, STEPS/SPM, LEVEL, STRIDE will show up in the display window. Press MODE button and you can switch between TIME and STEPS.
6. During workout, the TIME or STEPS in the display window will be counting down. When your desired TIME or STEPS is reached, a beep will sound for 1.5 seconds, after which the display TIME and STEPS will begin to count up.

SET:

1. While you are in the MAN'L mode, press and hold the MODE key for 3 seconds and SET will appear in the display. You may now input your personal data. If you do not press any keys during this step, PRESS ENTER will appear to prompt you to input your data, then the display will automatically return to the SET screen. Press the ENTER key to input your WEIGHT.
2. When the display window appears "Press ▲▼ TO SELECT KG/LB", use the ▲▼ button to choose KG/LB. If you don't press any keys, the word PRESS ENTER will be shown to prompt you to choose one or the other, and will then return to the KG/LB screen.

3. Next you will be prompted to input your weight. The default starting weight (either 66 LB or 30 KG) will be displayed. Press ▲▼ keys to change the weight. Pressing the key once changes the weight 1 LB or 1 KG. Holding the key down will change the weight 5 LB or 5 KG every 0.5 seconds. The weight range available is 66-330LB and 30-150 KG. When you have set your desired weight, press ENTER to confirm it and the system will record it automatically. If you don't press ENTER to confirm the data, PRESS ENTER will appear in the display to prompt you to press ENTER, and then the display will automatically return to the weight data window.

STRIDE ADJUSTMENT

1. Press the STRIDE ▲▼ keys to adjust stride length. The stride length range is between 450 mm ~ 650 mm (17" ~ 26").
2. The STRIDE window will display SPM (STRIDES/MIN).

PROGRAM

1. Press the PROGRAM button to scroll between the (3) Program. When you have selected the program you want, press the "ENTER". You will be prompted to "PRESS ▲▼ TO SET TIME/STEPS". The display window now will stay at TIME MODE with TIME lit up and STEPS not lit up, you can use MODE ▲▼ buttons to switch to STEPS if you wish. Finally, press ENTER to confirm your choice on TIME or STEPS MODE. Again, use MODE ▲▼ buttons to set your desired TOTAL STEPS or TIME and press ENTER to confirm. If you don't press ENTER, the display will remind you to "PRESS ENTER".
2. The program profile will be displayed in the LED window, and the program will begin when you start stepping. If you don't begin stepping immediately, you will be prompted to "STEP TO START".
3. During these programs, the unit will automatically switch between levels, varying from your workout.
4. When your desired STEPS or TIME is reached, a beep will sound for 1.5 seconds, after which the machine will begin to count up.

The course profiles for each program are as follows:



Even though the programs feature pre-programmed levels, you can change the level anytime during your workout. If you stop in the middle of your workout, you will be prompted to "STEP TO START". All input data (TIME, STRIDE LENGTH, LEVEL, STEPS, CAL., etc.) will be retained.

USING THE INTERVAL MODE

1. The elliptical trainer includes a custom INTERVAL program which allows you to design your own personalized workout program. There are 8 programmable segments in the Interval mode.
2. Press the PROGRAM key until INTV appears in the display. Press ENTER to choose INTV. If you don't press ENTER, the display will remind you to "PRESS ENTER".
3. After pressing ENTER, SEG:1 will appear in the window. You can set the SEGMENT 1 workload now.
 - 3.1 TIME and LEVEL default settings appear in the window (or, if you have used this INTV before, the settings from your previous workout appear).
 - 3.2 Press the MODE ▲▼ keys to adjust time.
 - 3.3 Press the LEVEL ▲▼ keys to adjust resistance.
 - 3.4 Press ENTER to confirm your settings. If you don't press ENTER, the display will remind you to "PRESS ENTER".

After you press ENTER, SEG:2 will appear in the window. Repeat the steps above for Segments 2-8. If you don't want to set all 8 segments, you can set the TIME for the final segment to zero. For example, if you only want to set four segments, leave segment 5's TIME with a value of zero, and the Elliptical 807P will use only the first four segments.

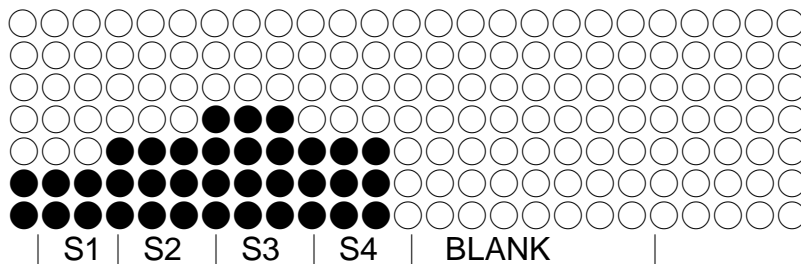

4. Once you have set all desired segments, press ENTER one last time, and your own personalized program, under INTERVAL, will be appeared in the window.
5. You can change the load level anytime during your workout by pressing the LEVEL ▲▼ keys.
6. If you stop in the middle of your workout, you will be prompted to "STEP TO START", then the display will automatically return to the former display window. All input data (TIME, STEPS, CAL., LEVEL, etc.) will be retained.
7. When you have completed your INTV workout, the electronics will beep for 1.5 seconds, then will automatically return to the MAN'L mode.

RESET

1. TO STOP: When you are in STRIDE motion, press RESET to stop motor.
2. TO CLEAR ALL DATA: Press the RESET key to clear all data and return to the MAN'L mode.

KEY FUNCTIONS (definitions):

TIME: Use the Mode ▲▼ keys to set the desired time of your workout. Each press of the key changes the time in increments of 1 minute. Pressing and holding the key will change the display by 5 minutes every 0.5 seconds. When you have reached your desired time, press ENTER.

During your workout, the electronics package will count down, and then beep for 1.5 seconds when your desired time is reached. If your workout continues, the unit will start to count up.

STEPS: Use the Mode ▲▼ keys to set your desired steps. Each press of the key changes the steps in increments of 5 steps. Pressing and holding the key will change the display by 50 steps every 0.5 seconds. When you have reached your desired steps, press ENTER.

During your workout, the electronics package will count down, and then beep for 1.5 seconds when your desired steps have been reached. If your workout continues, the unit will start to count up.

CAL.: This readout gives you the amount of calories burned, based on the weight you entered and the steps during your workout.

SPM: This readout displays the steps per minute.

STRIDE: The stride length range is 450 mm ~ 650 mm (17" ~ 26"). Press the STRIDE ▲▼ keys to adjust the stride length.

HEART RATE CONTROL (HRC) FEATURE : (If applicable)

1. Press the PROGRAM button until HRC appears on the display.
2. Press "ENTER" to select Heart Rate Control. Press ▲▼ to select FAT BURN or CARDIO, then press ENTER to record your choice.
3. "INPUT YOUR AGE" will show in the window and followed "AGE35" appears on the screen. Press either ▲ or ▼ to set your age. After you pressed ENTER, your target heart rate will appear in the Pulse window.
4. Press ENTER and you then have the option of modifying your heart rate limit. "MODIFY YOUR HEART RATE LIMIT" appears and "MODIY" stays in the display. You can lower your heart rate limit using the MODE ▲▼ key, but you can't increase the prescribed limit.
5. Press ENTER and "INPUT TIME IN THE TARGET ZONE" displays and "TIME" appears on the screen. You may now set how much time you want to spend in your Target Zone. Use the MODE ▲▼ keys to set your time from 05:00 to 99:00 minutes. The minimum time is 5 minutes.
6. After your desired TIME is selected, press ENTER. Then your Heart Rate Control program will begin. The program starts from level 5 tension. Your target heart rate will appear in the display as shown below:

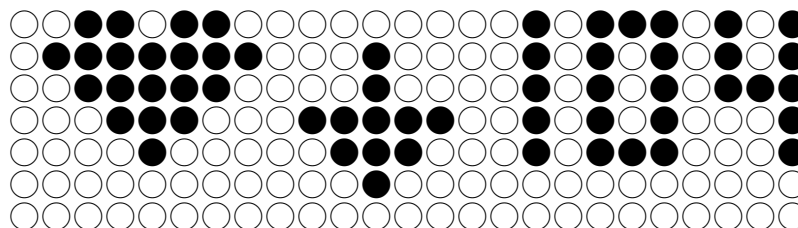

7. When you begin stepping, the Time will count up.
8. If you do not reach the speed indicators (bottom LED) to the arrow point, the display will prompt you to "SPEED UP" See Below:

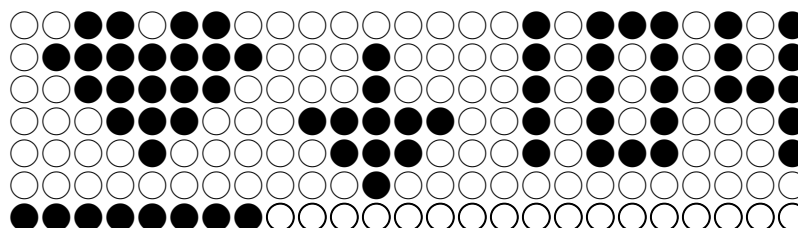

9. Once you are within 5 beats of your target heart rate, the computer will display: "HEART RATE CONTROL STARTING." and will beep for 3 seconds, then the computer controls your workout.
10. The Timer display will begin to count down from the Time in Target Zone you chose.
11. The HRC program will be terminated once the Time in Target 2 one counts down to zero. The Cool Down portion of the program is then activated, and you will hear a beeping sound for 1.5 seconds.
12. If the elliptical trainer gets no signal from the chest transmitter, the following will be displayed for 30 seconds:
"NO HEART RATE READING, PLEASE CHECK TRANSMITTER". After 30 seconds if no signal is received, the unit defaults to the "MANUAL" Mode.
13. If the user does not begin pedaling, the display will show "STEP TO START".

NOTE: " Due to the personal nature of HRC belt use, No HRC belt may be returned for any reason other than manufacturing defects.

GUIDELINES FOR EXERCISE

How long should I exercise?

The duration of your exercise session is depend on your fitness level. In general, it is recommended to maintain your heart rate in your training zone for at least 20 minutes to realize an aerobic benefit. It is recommended that before beginning any exercise program, you should consult with your doctor. This will aid in identifying your fitness level and how long you should exercise.

When first starting your workout, use the first several minutes to warm up, then slowly increase your workload. At the end of your workout, gradually decrease your workload, then exercise lightly as a cool down.

How often should I exercise?

Aerobic exercises, to achieve the greatest benefits, should be performed 3-5 times a week. It is important to allow sufficient time, at least 24 hours, for your body to recover after exercise.

MAINTAINING YOUR ELLIPTICAL TRAINER

Your elliptical requires little maintenance. The elliptical trainer's low friction operation is dependent on keeping the unit as clean as possible. See Cleaning the elliptical trainer for more information.

CLEANING YOUR ELLIPTICAL TRAINER

Regular cleaning is recommended to keep your elliptical trainer at peak performance. Before your workout, use a dry cloth to clean the surface of the electronics display.

Note: Never pour liquids on the electronics display. Should water, for some reason, get on the electronics package, immediately blow dry the electronics package.

To clean your elliptical, use a mild cleaner and for safety make sure the unit is completely dry before operating.

It is recommended that you keep all liquids away from the unit during operation. Spillage of liquids onto or into the machine will void the warranty.

Note: Execute the lubricating maintenance once per year, referring to the instructions attached.

1. (a) Follow the steps 1 and 2 to remove the access cap. (Point A is where to press in step 1) (see fig.11)
 - (b) By pressing the stride adjustment switch to level the nut, and posit the lubrication valve to middle. (see fig.11-1)
 - (c) Refilling with lubrication tube. (see fig.11-2)

(d) Follow the steps 3 and 4 to replace the access cap. (Point B is where to press in step 4) (see fig.11-3)

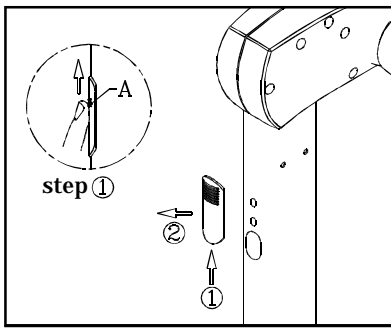

Fig.11

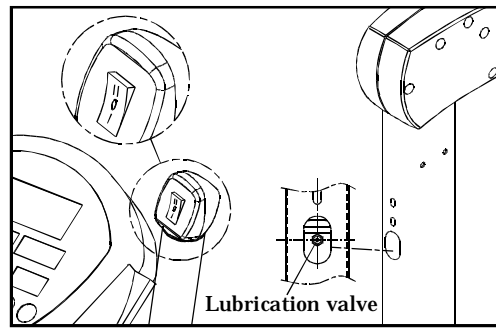

Fig.11-1

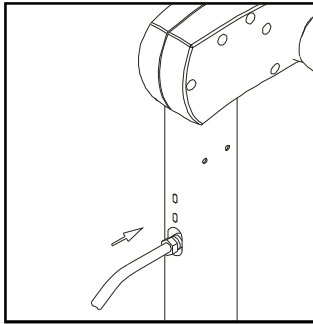

Fig.11-2

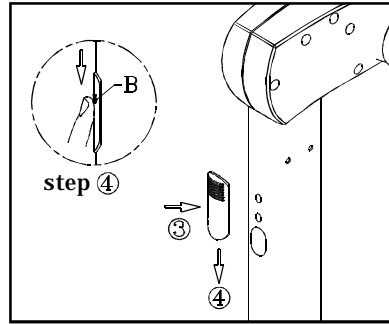

Fig.11-3

2. (a) Remove the access cap. (see fig.12)

(b) Refill with the lubrication tube and the lubrication valve. (see fig.12-1)

(c) Then, remove the lubrication tube. (see fig.12-2)

(d) Replace the access cap. (see fig.12-3)

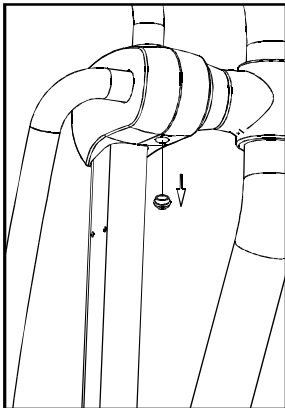

Fig.12

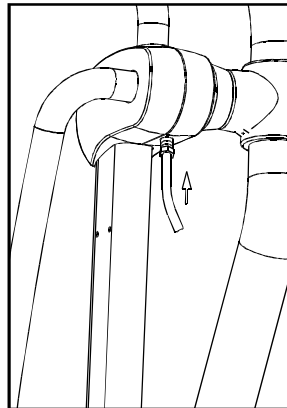

Fig.12-1

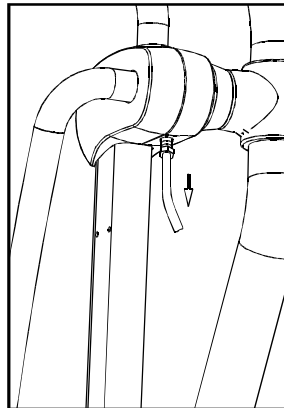

Fig.12-2

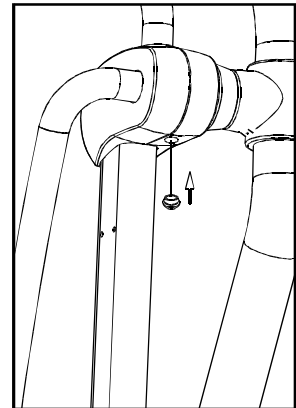

Fig.12-3

TROUBLE SHOOTING

(A). Blank display:

1. If you turn on the POWER switch and there is no light:
 - a. Check to make sure the power cord is plugged securely into the wall socket.
 - b. If the switch is still not lit, replace the fuse.

CAUTION: Make sure to unplug the power cord from the wall socket when replacing the fuse.

To remove:

Find the 1A fuse (100-120V)/1A fuse (200-220V) holder on the front of the machine, then push on the fuse holder and turn it counterclockwise to remove the damaged fuse (see Fig.13-1~13-2).

To install:

Insert a new fuse into the holder, push the fuse and holder into place, then turn the fuse holder clockwise to secure it (Fig. 13-3~13-4).

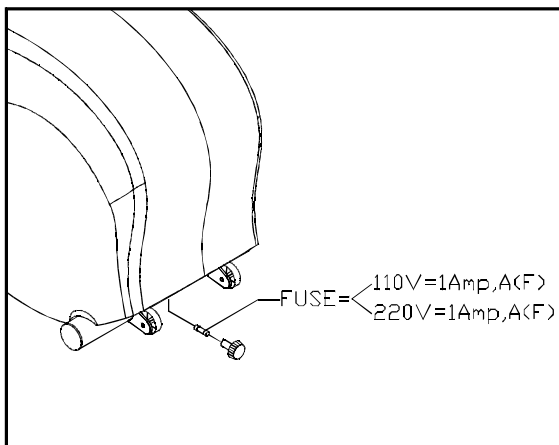

Fig.13-1

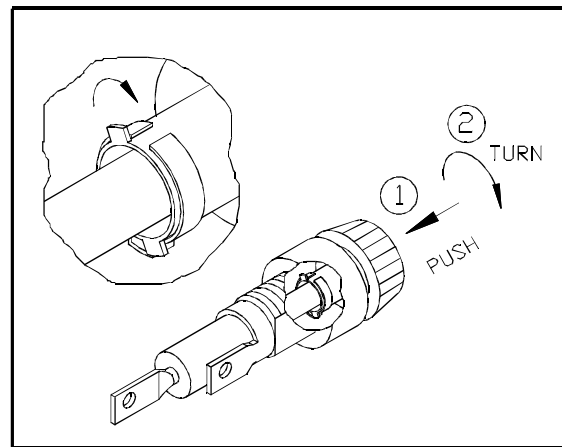

Fig.13-2

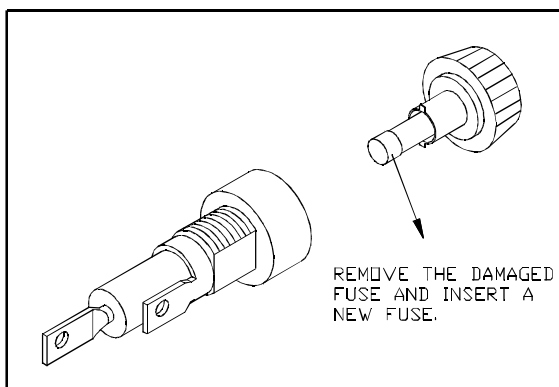

Fig.13-3

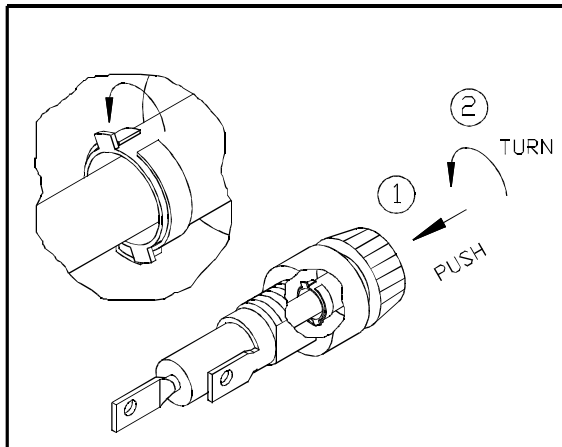

Fig.13-4

2. If you turn on the POWER switch and the switch is lit, but there is no display, please contact your dealer for more information.

(B) ERROR 7 MESSAGE: STRIDE ADJUSTMENT MALFUNCTION

ERROR 7 is a self diagnostic code to alert you to a problem with the electronic stride adjustment mechanism.

1. If you turn on the unit and ERR 7 appears on the display.
2. When you are using the STRIDE ▲▼ keys to adjust the stride length, the stride adjustment does not work, and ERR7 appears on the display.

Please contact your dealer immediately, and DO NOT use the unit, as the stride adjustment mechanism is damaged and must be repaired or replaced.

Caution: If ERR 7 appears and blinks for couple of seconds then the display will return to the previous display, or when you press the STRIDE ▲▼ keys to adjust the stride length and ERR 7 appears and blinks, please contact your dealer for further information because the stride system is damaged and should not be used.

(C). THE LOAD DOES NOT RESPOND PROPERLY:

If there is no load or the load does not respond properly when you press the LEVEL keys, please contact your dealer for further details.

(D). NO SPM READING:

If your display has no SPM reading during your workout, please contact your dealer for more details.

Cautions: Do not attempt to repair or service the elliptical trainer, unless you are a factory authorized service professional. Such an attempt will automatically void the factory warranty.

